

Specification

- Face to face according to DIN3202-K3;GB12221-16;
- Flange drilling according to ANSI125/150;DIN2501PN10/PN16;AS2129 Table E;JIS10K ect.
- Working Pressure: PN10;PN16
- Materials: GG25, GG40.3, A126, WCB, CF8, CF8M, CF3M, ect.
- Seat: NBR, EPDM, VITON, PTFE METAL/METAL

Application

Valve is used for preventing the back-going of medium in pipelines and equipments, and the pressure of medium will bring the result of opening and closing automatically. When the medium is back-going, valve disc will automatically closed to avoid accidents.

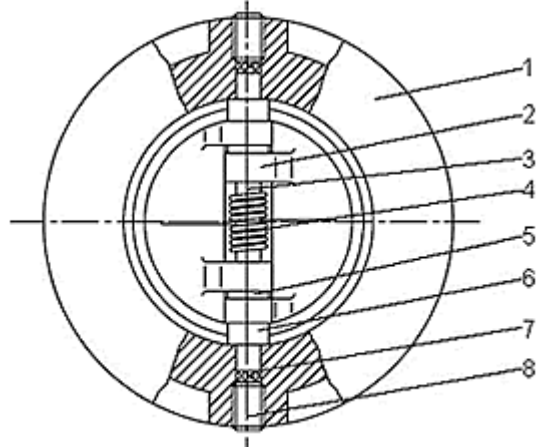
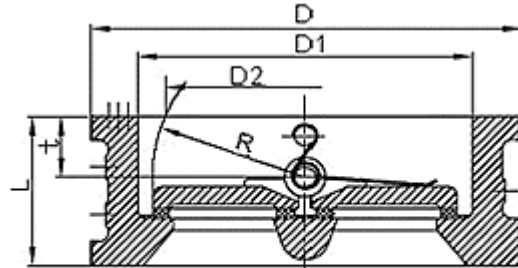

Materials

NO.	NAME	MATERIAL
1	Body	GG25
2	Disc	SS316
3	Stem	SS410
4	Spring	SS304
5	Washer	PTFE
6	Washer	PTFE
7	Gasket	NBR
8	Hex nut	A193A

Dimensions

DN	D	D1	D2	L	R	t
50	107	65	40	43	27	18.4
65	127	80	60	46	35	19.8
80	142	94	70	64	42	27.7
100	162	117	88	64	50	27.7
125	192	145	115	70	64	30.3
150	218	171	134	76	77	31.6
200	273	224	182	89	102.5	32.9
250	328	265	220	114	125	50.5
300	378	310	260	114	146	43.3
350	446	360	298	127	170	45.3
400	488	410	350	140	195	52.3
450	546	450	385	152	215	58.2
500	594	505	438	152	238	58.3
600	700	624.5	538	178	292	74.6